



Advait Gangal

advait.gangal@wetsus.nl

Motivation

Biological Activated Carbon (BAC) filters are noted for their ability to remove organic micropollutants (OMPs), compounds that can be harmful to human and environmental health^{1,2}. The augmentation of biological activity to the adsorption process in granular activated carbon (GAC) filters may open new pathways for OMP removal, which remain poorly understood within the BAC filter.

This project aims to assess the validity and impact of interdependent removal processes in the BAC filter, and to construct a model that integrates these processes in a dynamic operation so that the performance of BAC filters may be optimised.

Technological challenge

The several processes hypothesised to be involved in OMP removal in BAC filters² are illustrated in Fig. 1.

Among them, biodegradation refers to the co-metabolism of OMPs with other more abundant energy sources like ammonia or organic carbon. Alongside adsorption, this is expected to be one of the key processes driving OMP removal in BAC filters. It remains unclear, however, to what extent each of these processes affects the removal of OMPs in this integrated system. The contributions of other removal processes, such as chemical oxidation in highly oxygenated water, are also not yet understood. Furthermore, the limited understanding of the transformation products of the OMPs in this context raises concerns about whether their original toxicity is effectively mitigated. These factors impede the development of a robust and adaptable model.

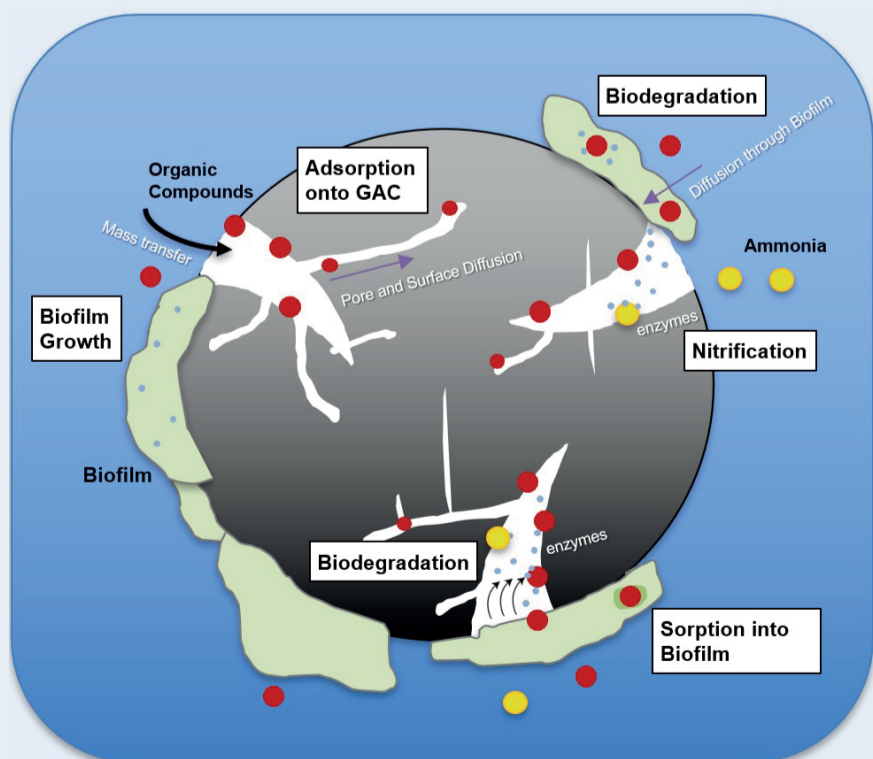

Fig. 1: Illustration depicting the several processes occurring in and around a BAC granule that contribute towards contaminant and OMP removal.

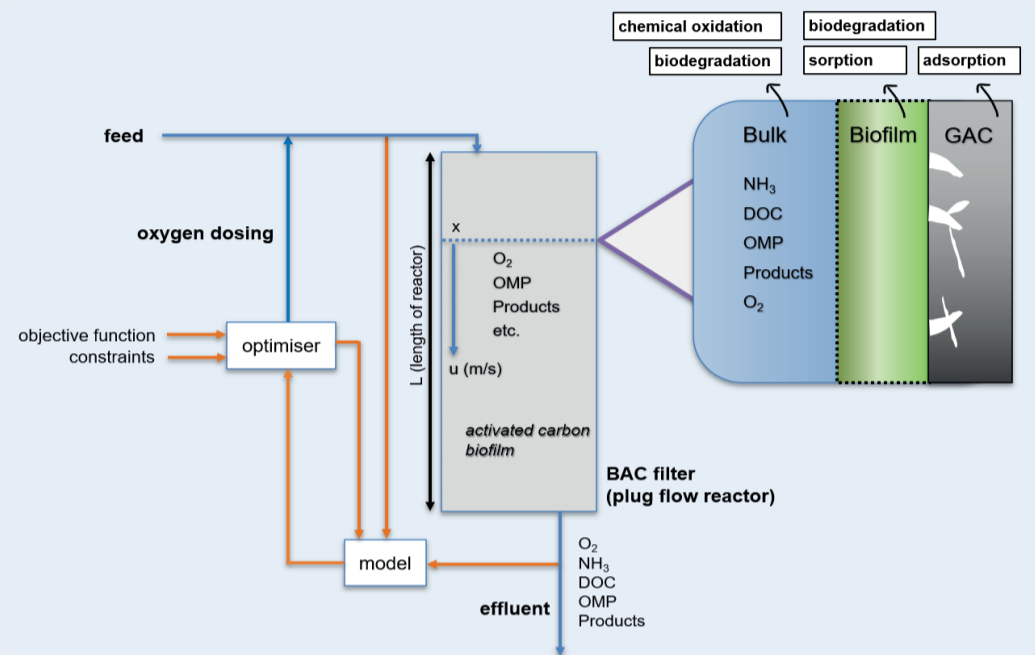

Fig. 2: Schematic of the proposed digital twin of the BAC filter. The control loop incorporates the model into the digital twin. On the right, the various OMP removal processes are labelled according to the various phases in the BAC filter in which they occur, and so integrated into the model.

Research goals

The project seeks to describe each individual process (Fig. 1) within a mathematical framework and assess its impact on effective OMP removal in the context of BAC filter conditions.

The interplay between these processes can then be considered. For instance, biodegradation may partially remediate used sites in the GAC, allowing fresh adsorption again.

The aspirational goal of this project is to integrate relevant processes into one dynamic mechanistic model that can reliably predict OMP removal in BAC filters. In this way, the performance of BAC filters can be optimised both in design and in real-time by controlling system parameters like oxygen dosage and backwash frequency with changes in influent load and hydraulic head among other factors. A digital twin of the BAC filter can thus also be operated alongside the physical filter operation (Fig. 2).

[1] J. P. Gutkoski, E. E. Schneider, C. Michels, Journal of Environmental Management. 349, 119434 (2024).
 [2] O. Bernadet, A. Larasati, H. P. J. Van Veelen, G. J. W. Euverink, M. C. Gagliano, Journal of Hazardous Materials. 458, 131882 (2023).